



# LineAr 100 VA rainwater filter

Filter system for installation in the access shaft of underground rainwater storage tanks



## INSTALLATION AND OPERATING INSTRUCTIONS

- For pipe cross-sections up to DN 100
- Filter mesh size 0.37 mm
- Stainless steel filter insert
- Perfectly designed for retrospective installation in existing rainwater storage tanks
- Height difference only 52 mm

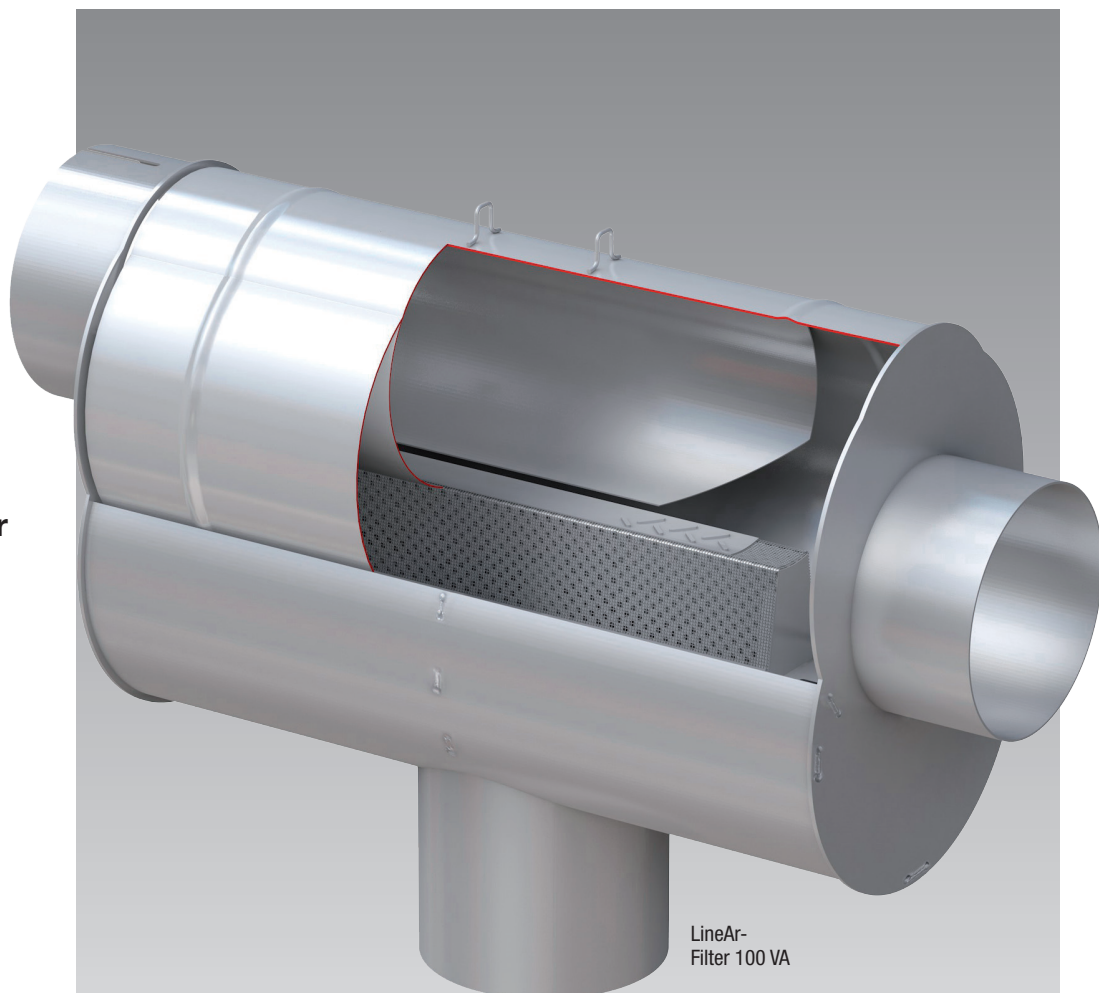

# WISY

## Rainwater Harvesting

# WISY LineAr 100 VA rainwater filter

Thank you for choosing a high-quality WISY rainwater filter system. Please read these instructions for your WISY rainwater filter before you begin installing it and keep them in a safe place for future reference.

## Contents

- Safety instructions
- Applications
- Guide to components
- Installation instructions
- Installation
- Cleaning the filter insert
- Example of a typical installation
- Accessories
- Guarantee

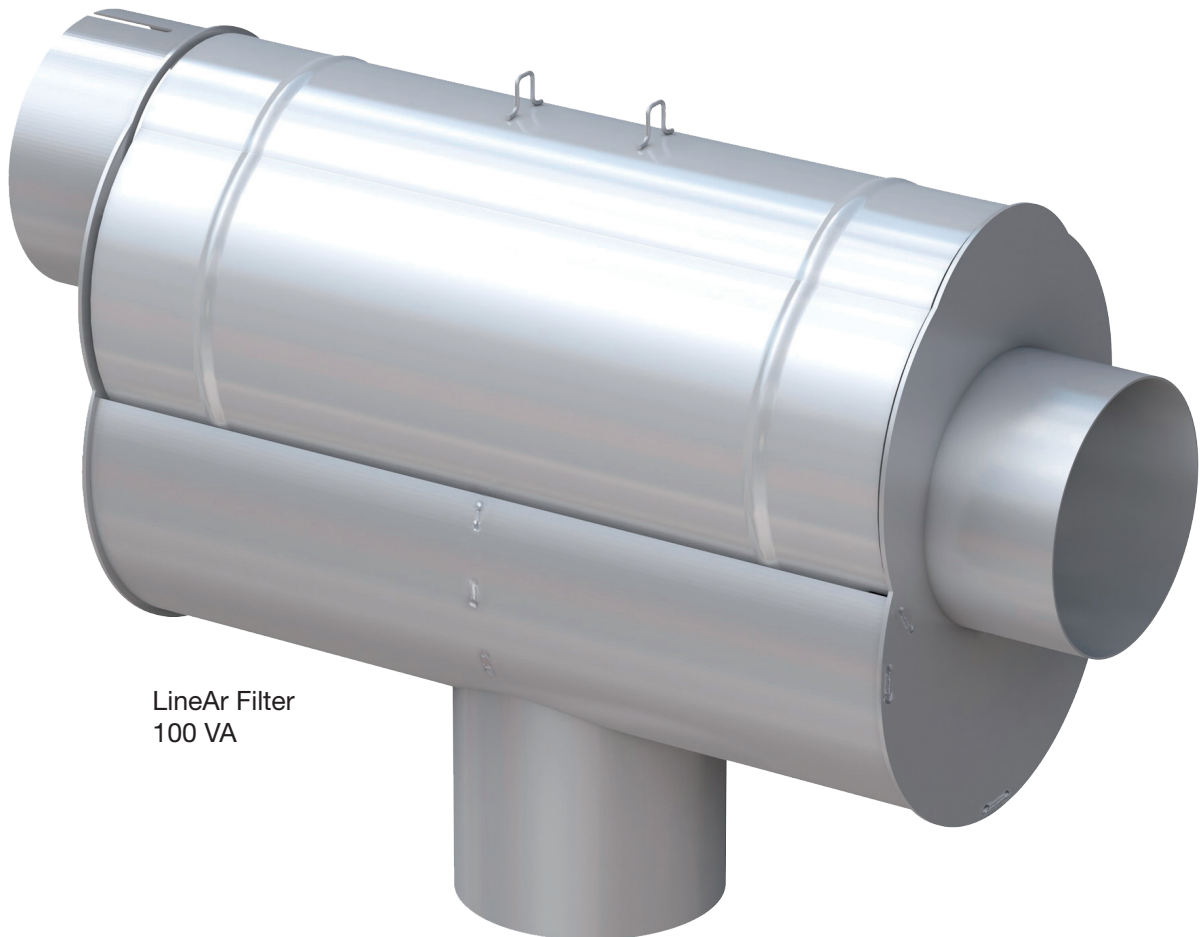

LineAr Filter  
100 VA

**Take particular care when transporting or carrying the LineAr 100 VA rainwater filter! You could suffer serious injury if the filter falls out of the housing!**

## **Safety instructions**

The WISY LineAr 100 VA rainwater filter consists of two parts, the filter housing and the filter element with filter insert. Take particular care when transporting and carrying the WISY LineAr 100 VA and never forget that the filter housing and filter element are not joined together.

If the filter element falls out of the housing, you or other persons could sustain serious injury and damage could be caused to the filter element. When persons with mental, physical or sensory disabilities handle the WISY LineAr 100 VA rainwater filter, they must be supervised by someone who is responsible for their safety. The potential hazards of handling the equipment must have been explained to them. Children must not be allowed to play with or operate the equipment, nor to carry out any maintenance on it.

## **Applications**

The WISY LineAr 100 VA rainwater filter has been designed for installation in the access shaft of rainwater storage tanks (including flat tanks). The small difference in height between the rainwater inlet and storm drain outlet makes it a perfect filter to replace existing systems which have a dirt trap or for retrospective installation in existing rainwater storage tanks that have been in operation without a filter. The LineAr 100 VA filters rainwater harvested from the roof through a horizontal rainwater drain pipe.

The difference in height between the rainwater inlet and the soakaway/storm drain connection is only 52 mm. The filtered water drops into the rainwater storage tank (through a pipe fitted with a calming device) while a small quantity of water is used to flush the debris through the outlet to the soakaway or storm drain. Thanks to the small height difference between the inlet and outlet, the LineAr 100 VA rainwater filter is ideal for retrofitting in existing systems or for installation in flat rainwater tanks.

The best roof areas are pitched roofs of slate, clay tiles, concrete tiles or membrane and sheet metal roofs. It must be taken into account that "green roofs" retain rainwater. We recommend that a pure, mineral-based substrate is installed beneath the growing medium layer of green roofs connected to a rainwater harvesting system in order to reduce the volume of turbid water washed out of the roof.

Substances washed out of roofs covered with bitumen felt can discolour the harvested rainwater.

# Guide to components

- 1 Filter housing
- 2 Filter element
- 3 Filter insert
- 4 Rainwater inlet DN 100
- 5 Outlet to rainwater tank (filtered water) DN 100
- 6 Outlet to soakaway or storm drain DN 100
- 7 Lugs for lifting handle
- 8 Lifting handle

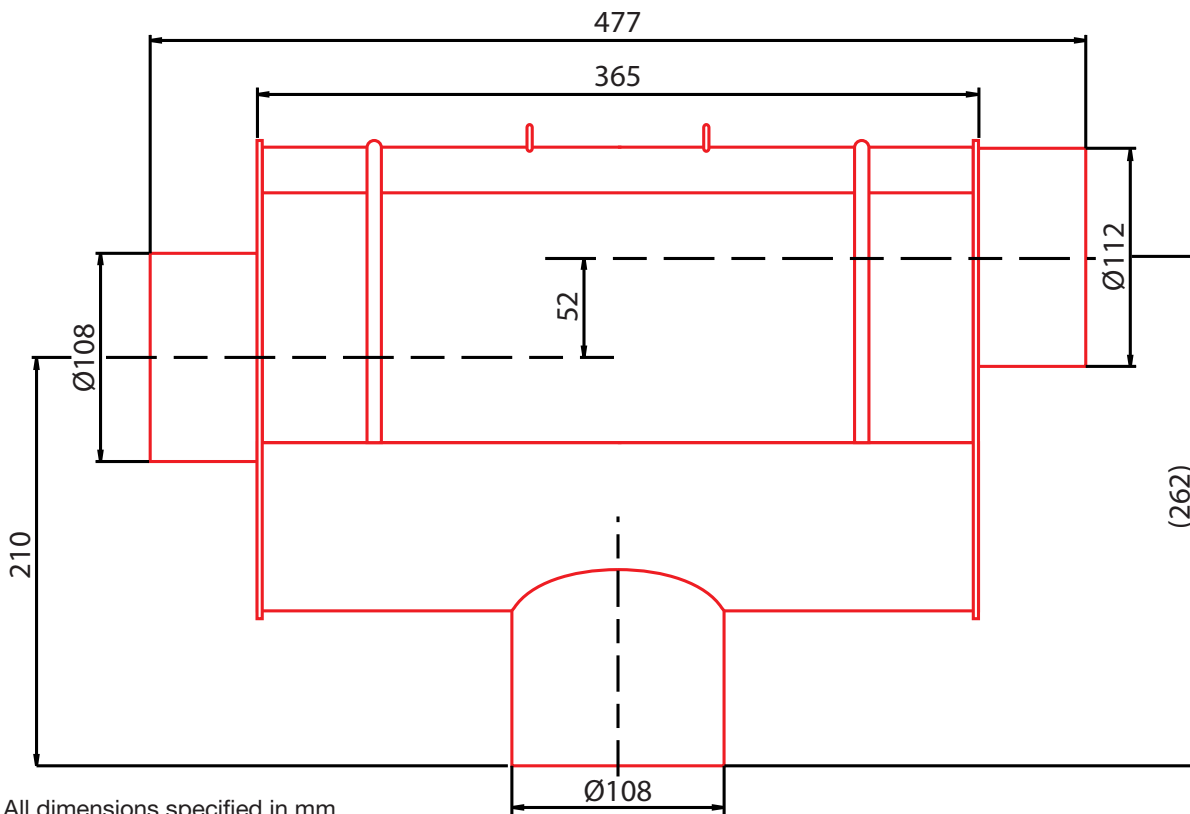
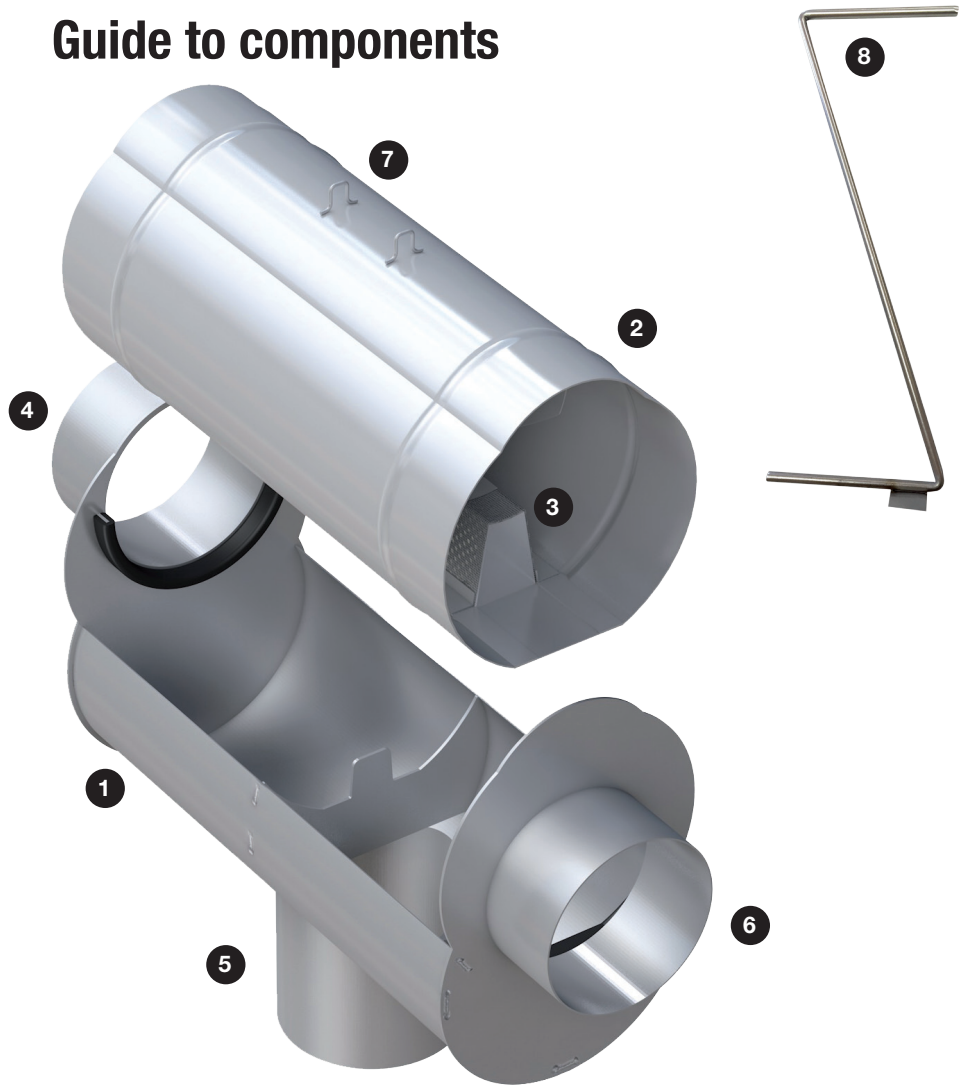

All dimensions specified in mm

DN = Diameter Nominal, abbreviation for nominal size

# Installation instructions

The inflow pipe must be installed at a gradient of about 1%.

The rainwater inlet must be a straight length of tube with an inflow calming section of at least 0.5 m in length. The LineAr 100 VA rainwater filter must be positioned in the access shaft of rainwater storage tanks

in such a way that the filter insert can be easily removed with the lifting handle for regular maintenance. It must be possible to lift out the insert from ground level without needing to climb into the access shaft or rainwater storage tank.

Before the filter is installed in an access shaft or rainwater storage tank, the height differential inside the LineAr 100 VA rainwater filter and the pipe gradient in the access shaft / rainwater storage tank must be taken into account. The internal height difference between the invert levels is 52 mm.

To ensure the free flow of water through the LineAr 100 VA rainwater filter, the nominal size of the soakaway/storm drain outlet pipe must not be smaller than the nominal size of the rainwater inlet pipe.

If the installation conditions do not meet the described requirements, or if the difference in invert levels makes use of the LineAr 100 VA rainwater filter impossible, we recommend that you install the WISY downpipe filter collector in the rainwater downpipe instead.

## Installation

The filter housing must be installed on the horizontal, the filtered water outlet must be aligned perpendicular (use a spirit level).

Before installation work commences, the filter insert must be removed from the LineAr 100 VA rainwater filter housing and stored safely in a clean place.

After the filter insert has been removed, the pipes can be connected to the housing of the LineAr 100 VA rainwater filter.

Make sure that **no stress is placed** on the connecting pipes.

The rainwater inlet is designed as a socket (collar) for insertion of a DN 100 pipe.

The inflow pipe should be inserted by 45 mm (minimum 40 mm, maximum 50 mm) into the socket.

The storm drain connection of the LineAr 100 VA rainwater filter must be connected to a socket.

The rainwater outlet DN 100 must be connected to a socket DN 100.

The LineAr 100 VA rainwater filter is correctly positioned when the rainwater outlet is aligned exactly perpendicular.

Once installation of the filter housing is complete, the filter insert can be placed inside.

**Important: Take care when placing the filter insert inside the housing and make sure that it is correctly positioned.**

When the installation work has been completed and the filter insert placed inside the housing, the LineAr 100 VA rainwater filter must be tested for proper functioning; the incoming water must flow as filtered water through the calming inlet into the rainwater storage tank.

## WARNING NOTICE:

**The WISY LineAr 100 VA rainwater filter is not a closed system. In the event of exceptionally heavy rainfall, a defect in the drainage pipes, a blockage in the drainage system, etc., there is a risk that water will escape from the LineAr 100 VA rainwater filter. We do not accept responsibility for any consequential damage.**





*Note: The filter insert can be easily fitted inside the filter housing but this must be done with care. When the filter insert is properly positioned, it should be correctly seated flush inside the housing.*

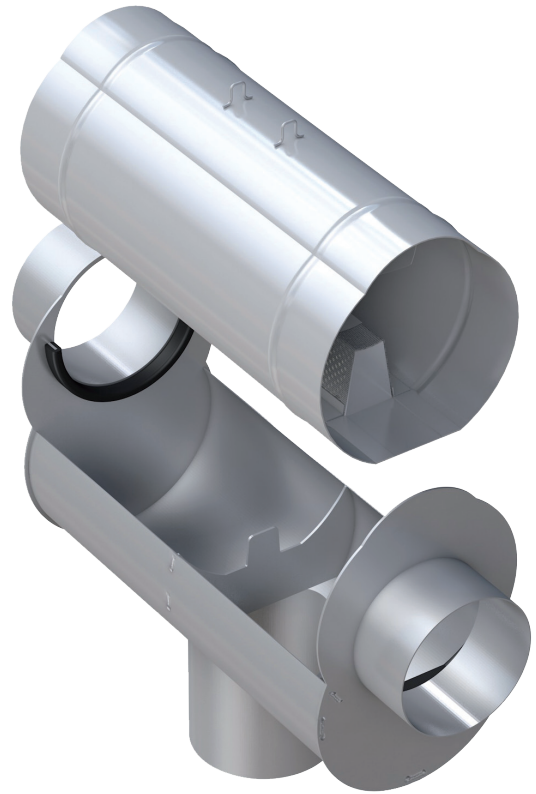

## **Cleaning the filter insert**

Place the lifting handle supplied through the lugs on top of the filter element and lift out the element.

We recommend cleaning at 3-month intervals. Some conditions may require the filter insert to be cleaned at shorter intervals,

while cleaning at six-monthly intervals is sufficient in other situations. Nevertheless, the filter insert should always be cleaned at intervals of at least six months.

Important: Make sure that the filter insert is positioned correctly when you place it back inside the housing. It must fit flush inside the housing.

**The filter insert can be cleaned easily and very effectively in a dishwasher. The filter mesh can also be cleaned manually using a dishwashing brush, warm water and commercial washing-up liquid in order to remove any greasy dirt.**

**Never leave the rainwater storage tank or access shaft unsupervised when it is open! Place the cover over the shaft or storage tank before you leave! Only specialist personnel are allowed to enter the rainwater storage tank or access shafts. These personnel must be supervised at all times and wear appropriate protective gear (e.g. recovery harness).**







A complete rainwater harvesting system with the WISY LineAr 100 VA rainwater filter inside a concrete storage tank.

Installed indoors is the Sigma rainwater unit for supplying rainwater to appliances.





### **Garantie**

Der WISY LineAr Filter 100 VA wird sorgfältig hergestellt und durchläuft strenge Qualitätskontrollen. Sollten sich trotz gewissenhafter Prüfung Mängel herausstellen, leisten wir Ersatz. Dies gilt jedoch nicht für Schäden, die durch unsachgemäßen Einbau oder Gewaltanwendung eintreten. WISY übernimmt 5 Jahre Garantie ab dem Datum des Kaufes vom Fachhändler. Innerhalb dieses Zeitraumes ersetzt WISY fehlerhaftes Material.

### **Guarantee**

The WISY LineAr 100VA rainwater filter is manufactured with care and subject to stringent quality controls. In the unlikely event that parts do prove defective despite our strict testing regime, WISY shall repair or replace free of charge any defective part. This does not apply however in the case of damage caused by improper installation or use of force. WISY offers a 5-year guarantee valid from the date of purchase from the specialist retailer. WISY will replace defective materials during this period.



**WISY AG**  
D-63699 Kefenrod, Oberdorfstraße 26  
Telefon +49 (0) 60 54-91 21-0

Fax +49 (0) 60 54-91 21-29  
Internet: [www.wisy.de](http://www.wisy.de)  
E-Mail: [info@wisy.de](mailto:info@wisy.de)